

The Innovator's Prescription: How Disruptive Innovation Can Transform Health Care

*Clayton Christensen
Harvard Business School*

cchristensen@hbs.edu

Centralization followed by decentralization: Computing

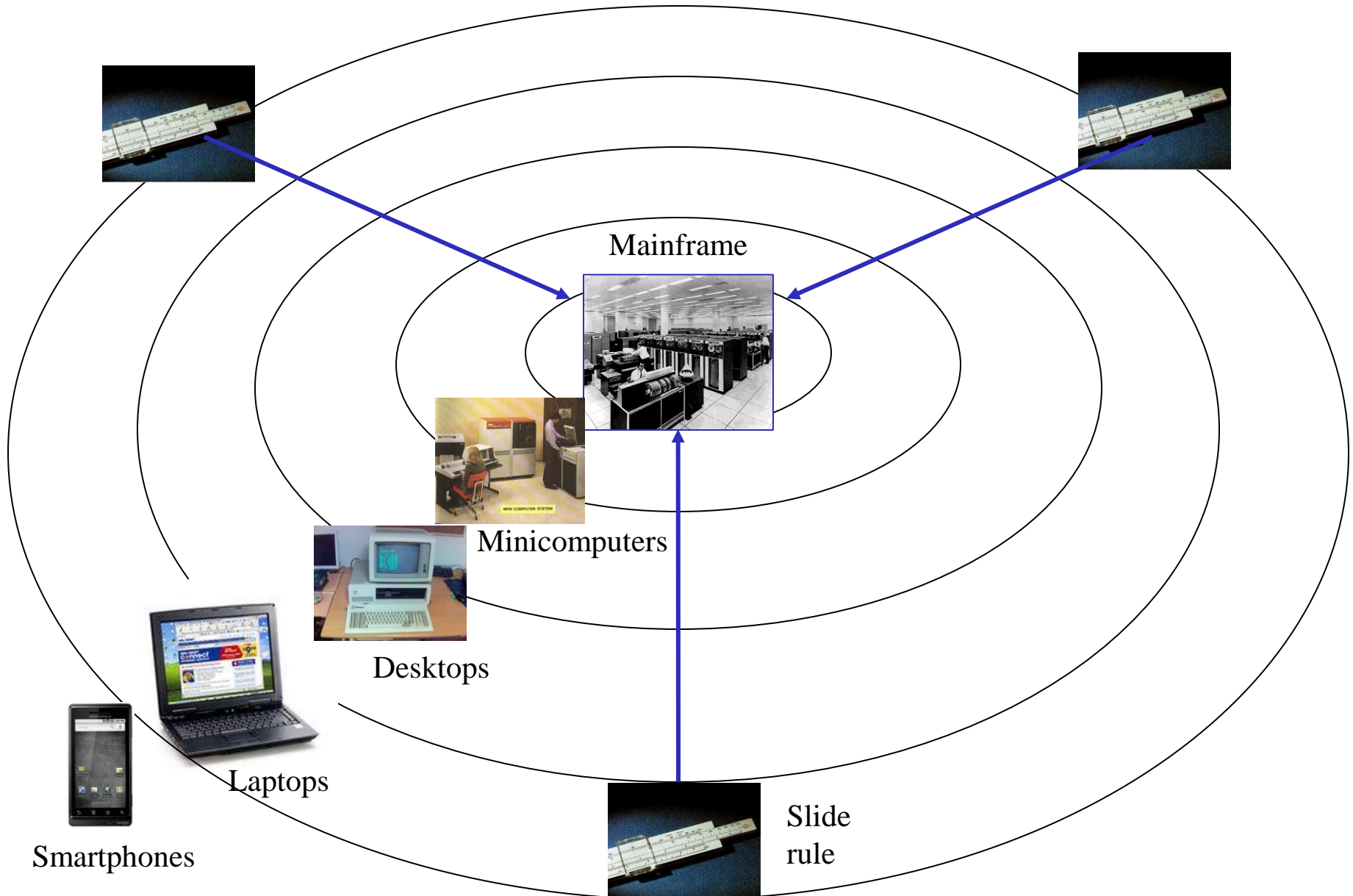

Decentralization is disruptive, and is hard to catch

*Incumbents dominate
sustaining battles*



60% on
\$500,000



45% on
\$250,000

Performance

Sustaining innovations

*Pace of performance
improvement*

*Ability to use
improvements*

Time

Disruptive Innovations

Time

*Entrants
typically win
at disruption*

40% → 20%
on \$2,000



Decentralization is disruptive, and is hard to catch

*Incumbents dominate
sustaining battles*

Performance

Sustaining innovations

Pace of performance
improvement

Ability to use
improvements

Time

Disruptive Innovations

Time

*Entrants
typically win
at disruption*

The decentralization that follows centralization is only beginning in healthcare

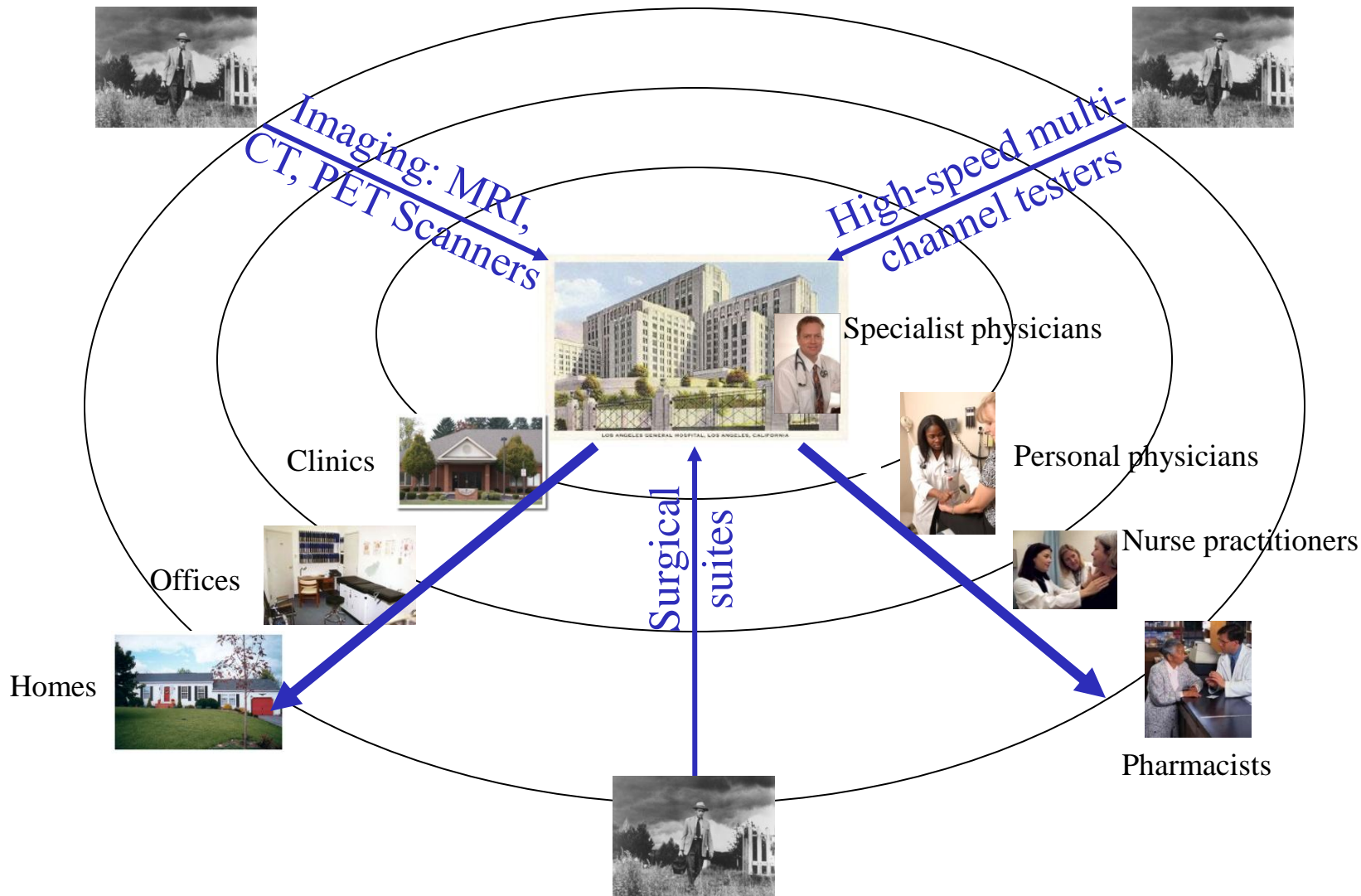

Enablers of Disruption

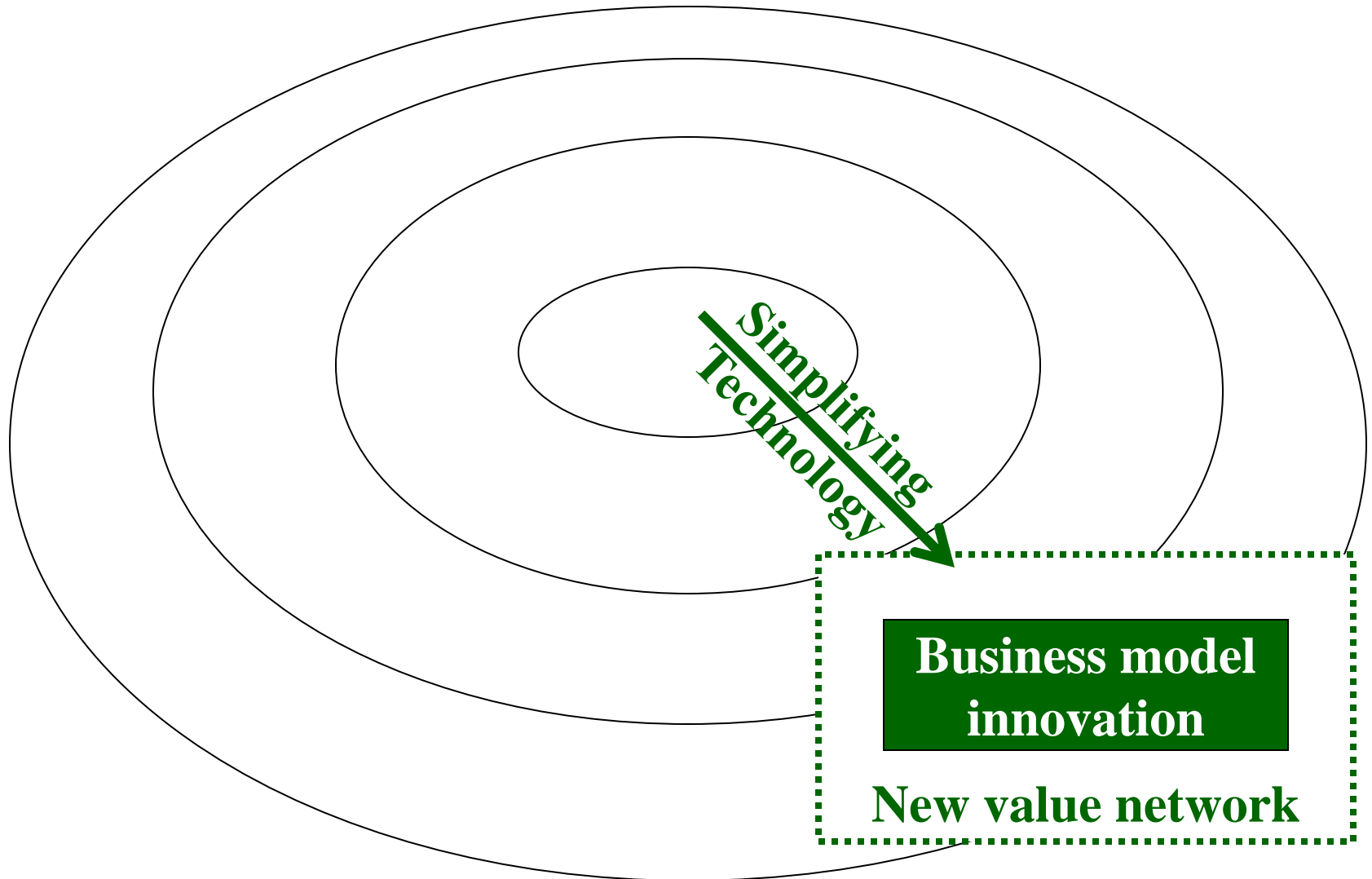

Scientific progress that commoditizes expertise plays a critical role in disruption

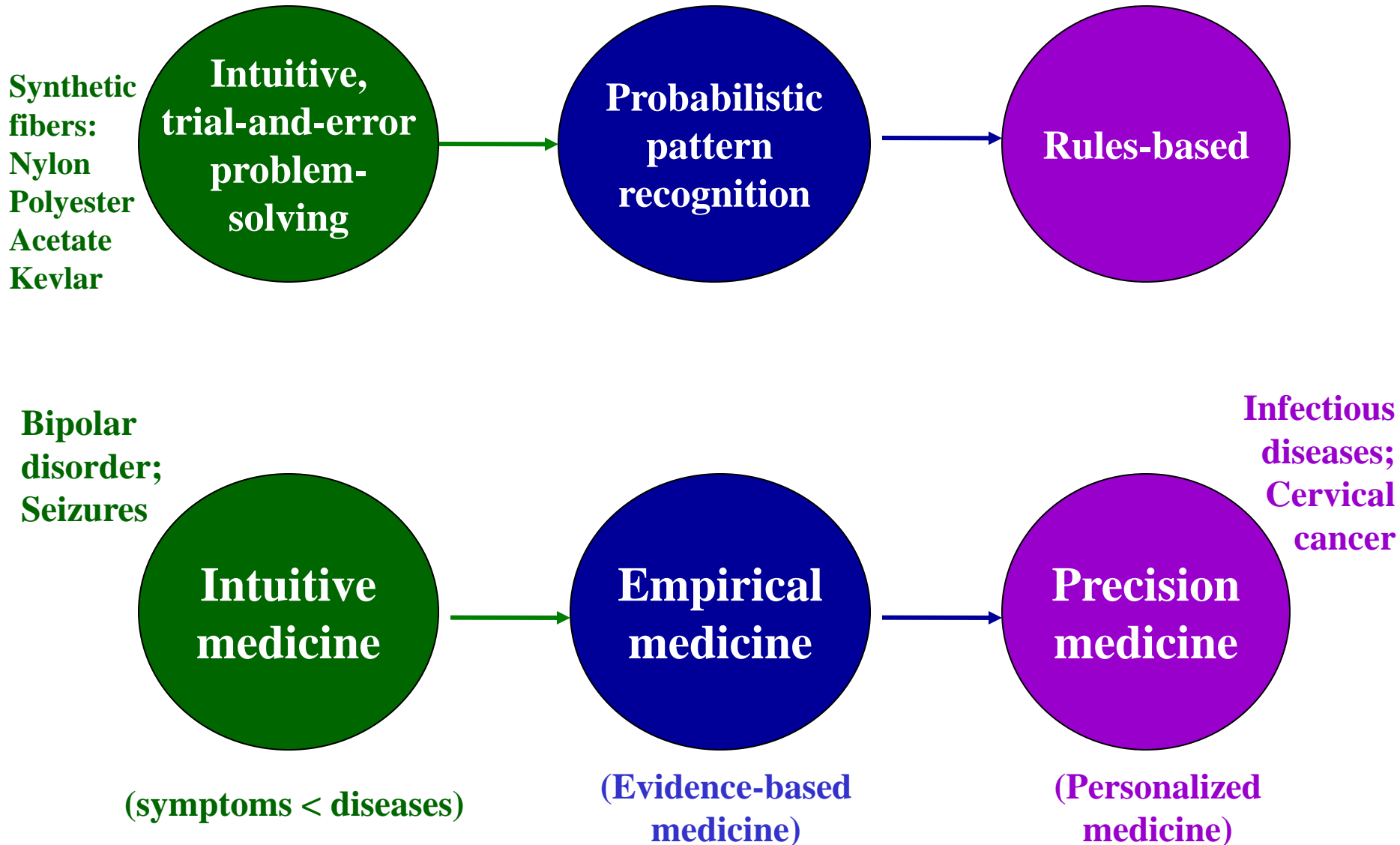

Public vs. Private Is the Wrong Categorization Scheme

Extent to which value can be specified, measured, priced, and captured by those who create it

Low

High

*15-40% lower costs
with better quality*

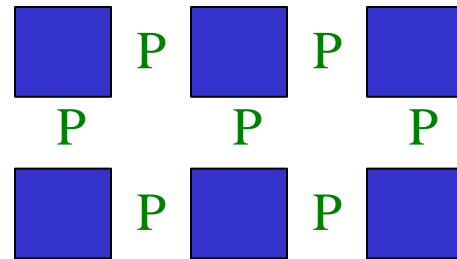
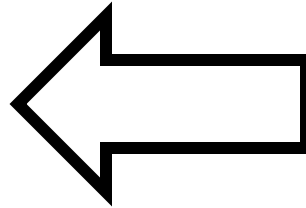
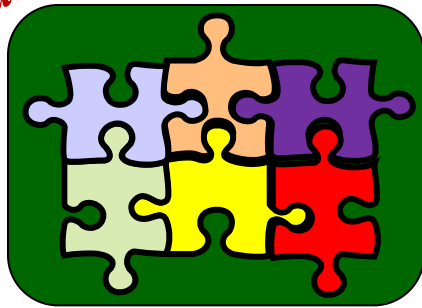

Systemically integrated

**Administratively
fragmented & specialized**

- Kaiser Permanente
- Intermountain
- HealthPartners
- Geisinger
- Employer-provided care
- Sweden, Finland

- 90% of USA
- Canada
- Germany
- Netherlands

What is a business model, and how is it built?

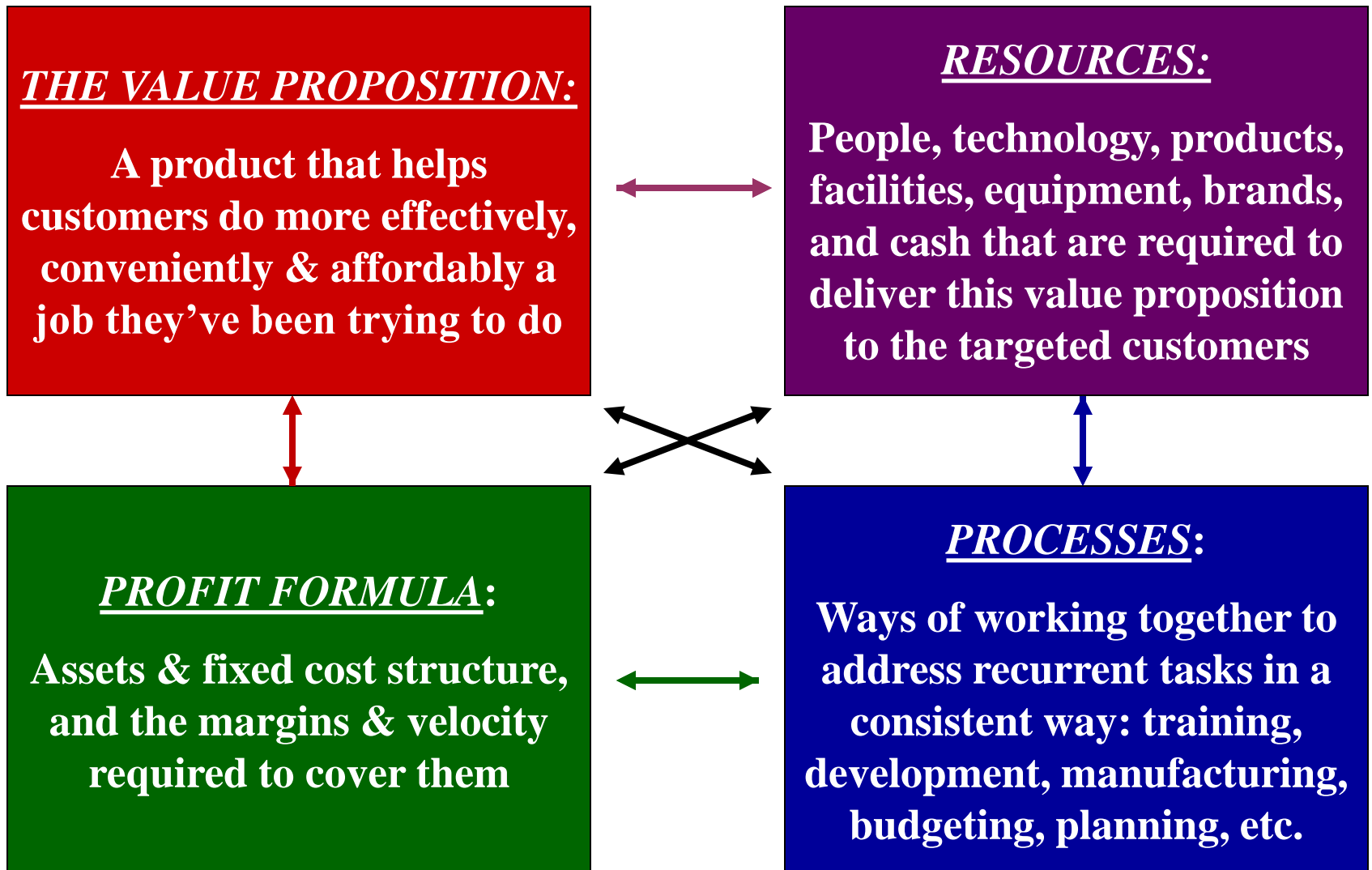

Hospital Expense Propositions of the very plain of this is as any body



SOLUTION SHOPS

- Consulting firms
- High-end law firms
- R&D organizations
- Diagnostic & intuitive activities of hospitals

FEE FOR SERVICE



START-AND-FINISH BUSINESSES

- Manufacturing
- Education
- Food services
- Construction
- Medical procedures

FEE FOR OUTCOME



FACILITATED NETWORKS

- Telecommunications
- Insurance
- EBay
- D-Life
- Crohns.org

FEE FOR MEMBERSHIP



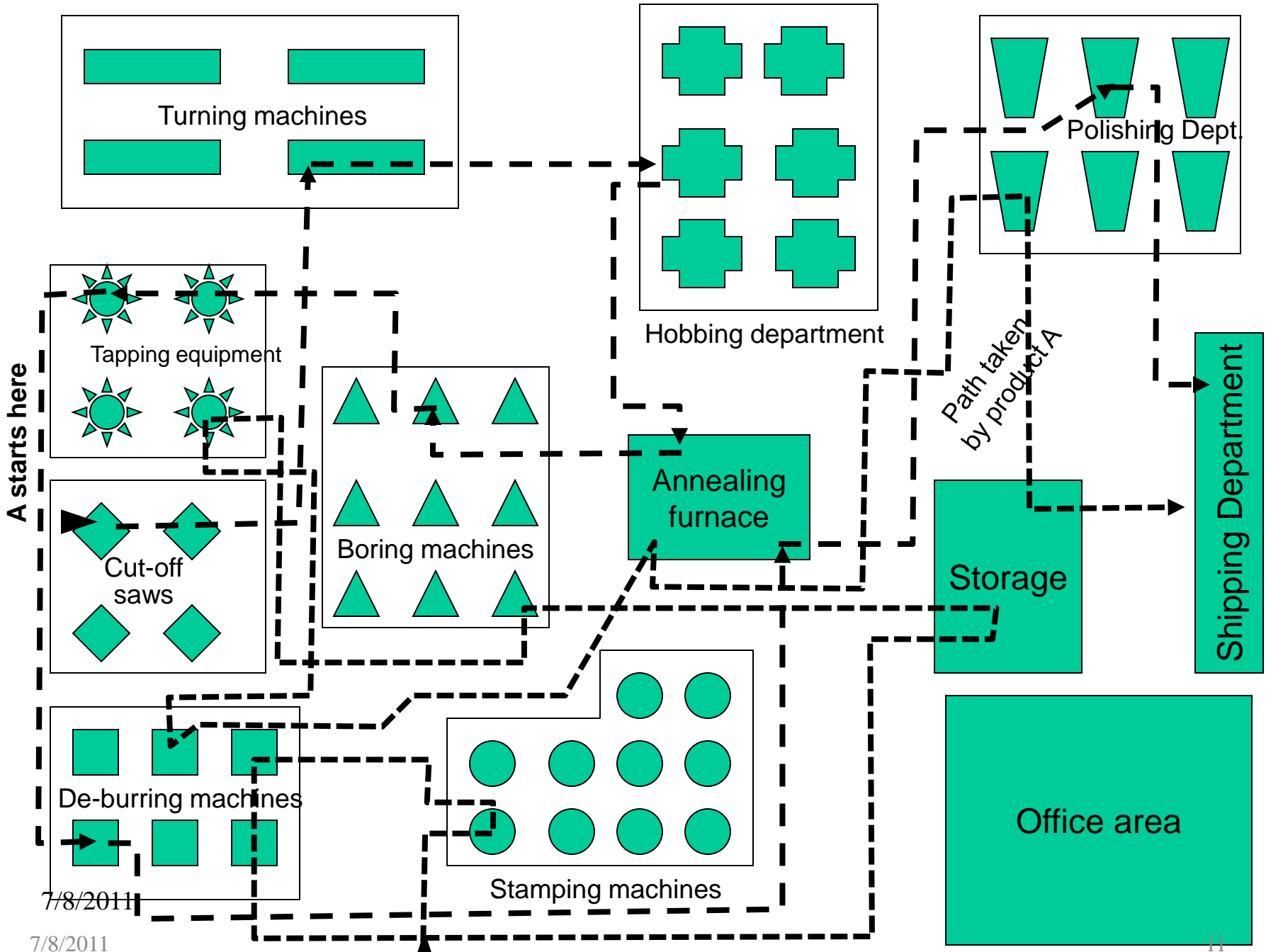

7/8/2011

7/8/2011

Disruption of the hospital business model

Today

Disjointed
VAP Clinic



Disjointed
Solution Shop



Dave Snow
CEO, Medco;
Asthma

Tomorrow

Coherent Solution Shops

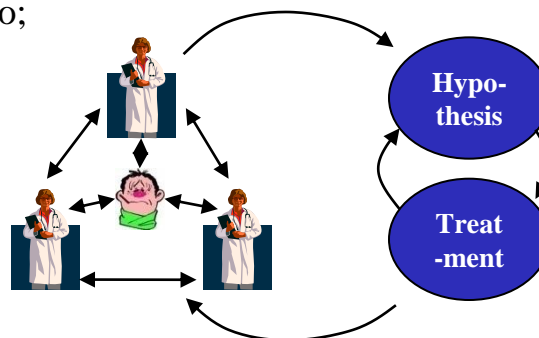

National Jewish Medical Center
Pulmonary & Respiratory Diseases

Need solution shops for:
Type II diabetes
Obesity
Depression
Schizophrenia
Epilepsy
Parkinson's disease
Ulcerative colitis
Chronic back pain
Alzheimer's disease

**Start-and-finish clinics:
Orthopedic, hernia, eye, etc.**



Sources & magnitude of cost differences: Specialty vs. General Hospitals

	Shouldice Hospital (hernia repair)	General Hospital
Cost of supplies & direct labor	\$700	\$970
Overhead burden	\$1600	\$6030
Total cost for equivalent length of stay	\$2,300	\$7,000
Service families offered	1	110

Retail clinics will disrupt primary care physicians' practices, pushing them up-market to disrupt specialists.



Market Understanding that Mirrors how Customers Experience Life



“The customer rarely buys what the company thinks it is selling him”

- Peter Drucker

Diabetes companies typically have targeted customers who don't own the job of keeping healthy.



Public vs. Private Is the Wrong Categorization Scheme

Extent to which value can be measured,
priced, and captured by those who create it

Low

High

*15-40% lower costs
with better quality*

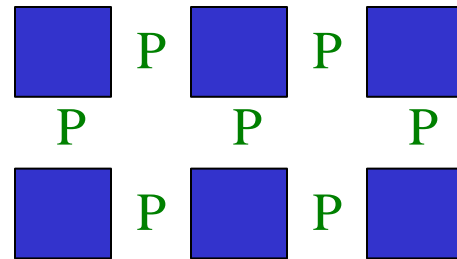
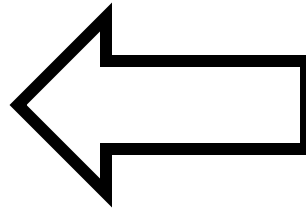
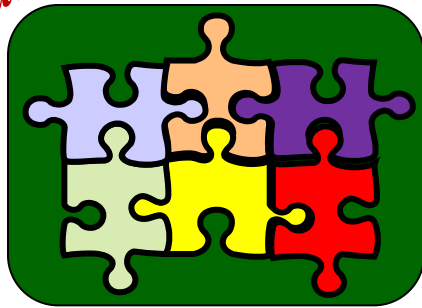

Systemically integrated

**Administratively
fragmented & specialized**

- Kaiser Permanente
- Intermountain
- HealthPartners
- Geisinger
- Employer-provided care
- Sweden, Finland

- 90% of USA
- Canada
- Germany
- Netherlands

Healthcare spending per capita, 2007
(US\$, PPP)

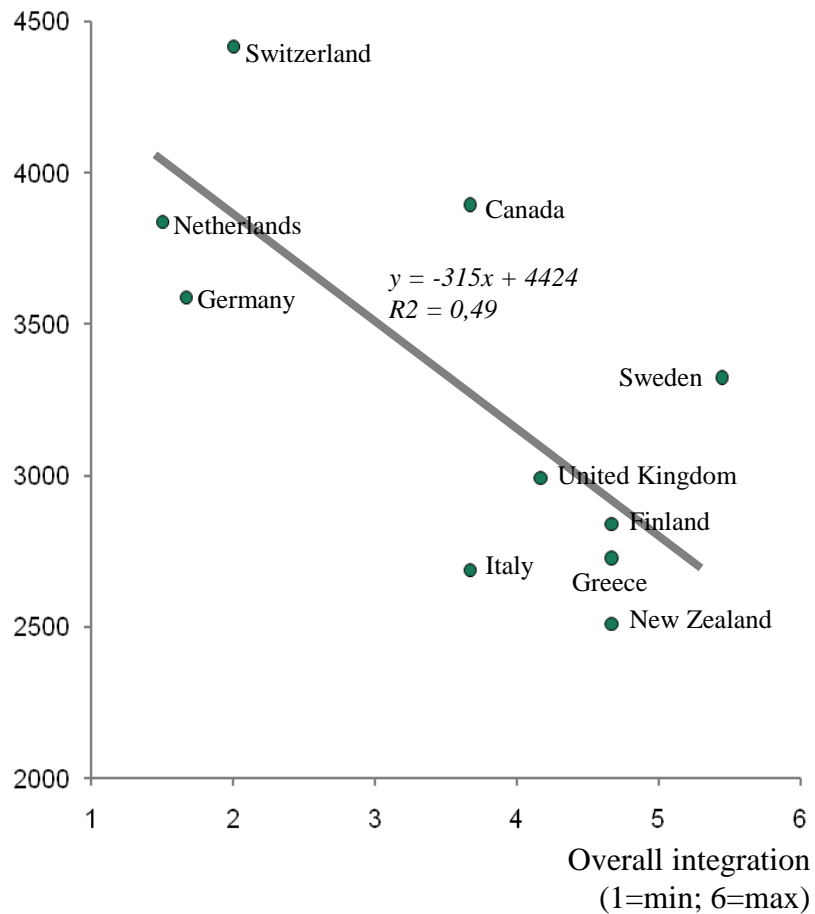

Healthcare spending, 2007
(percent of GDP)

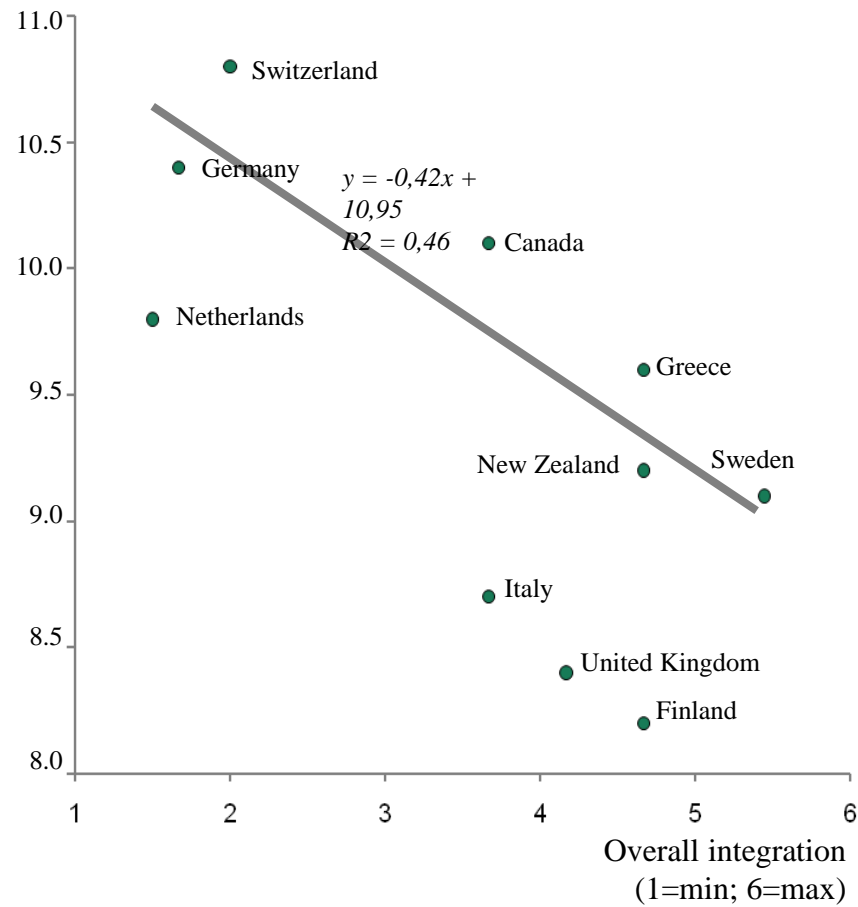

Note: overall integration score is average of payor-provider, provider-provider, and managerial integration scores. See following slides for details.

Changes in product architecture have profoundly changed the architecture of the computer industry

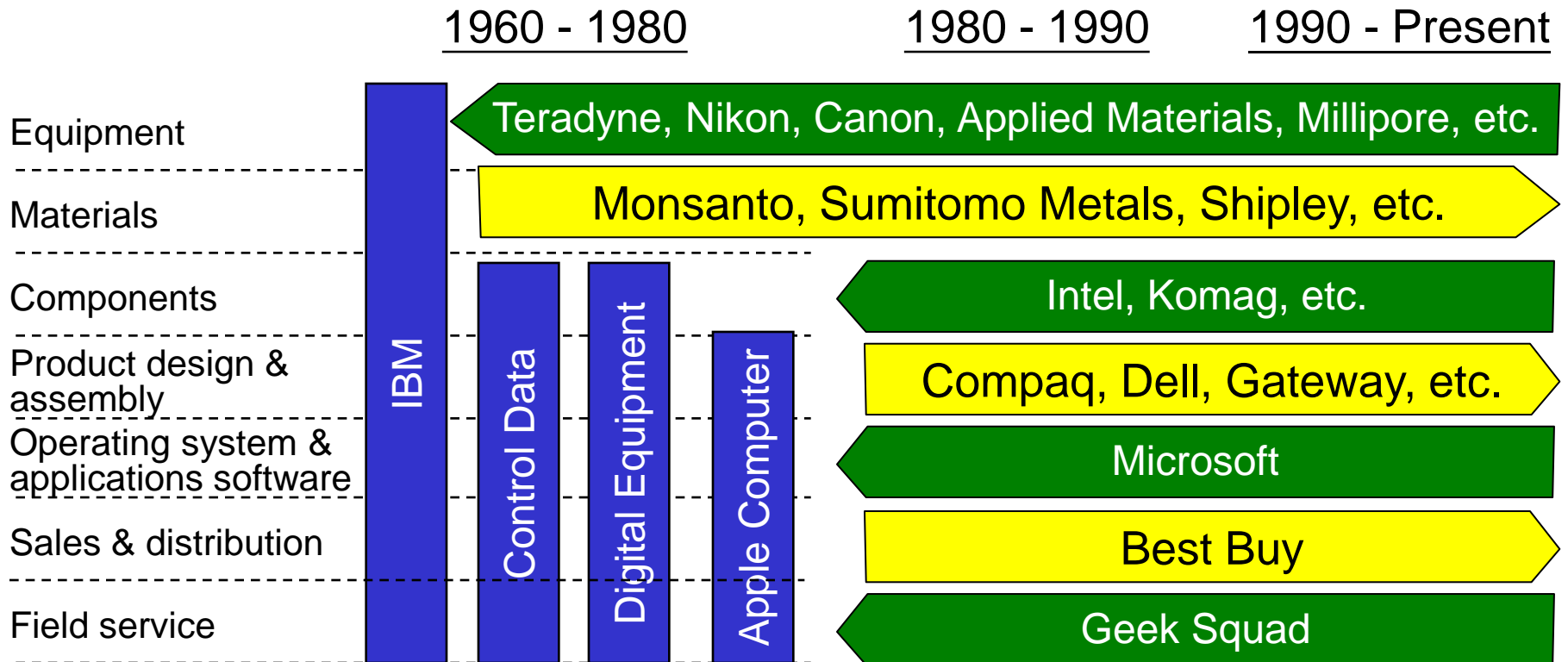

Business models for adherence in chronic care

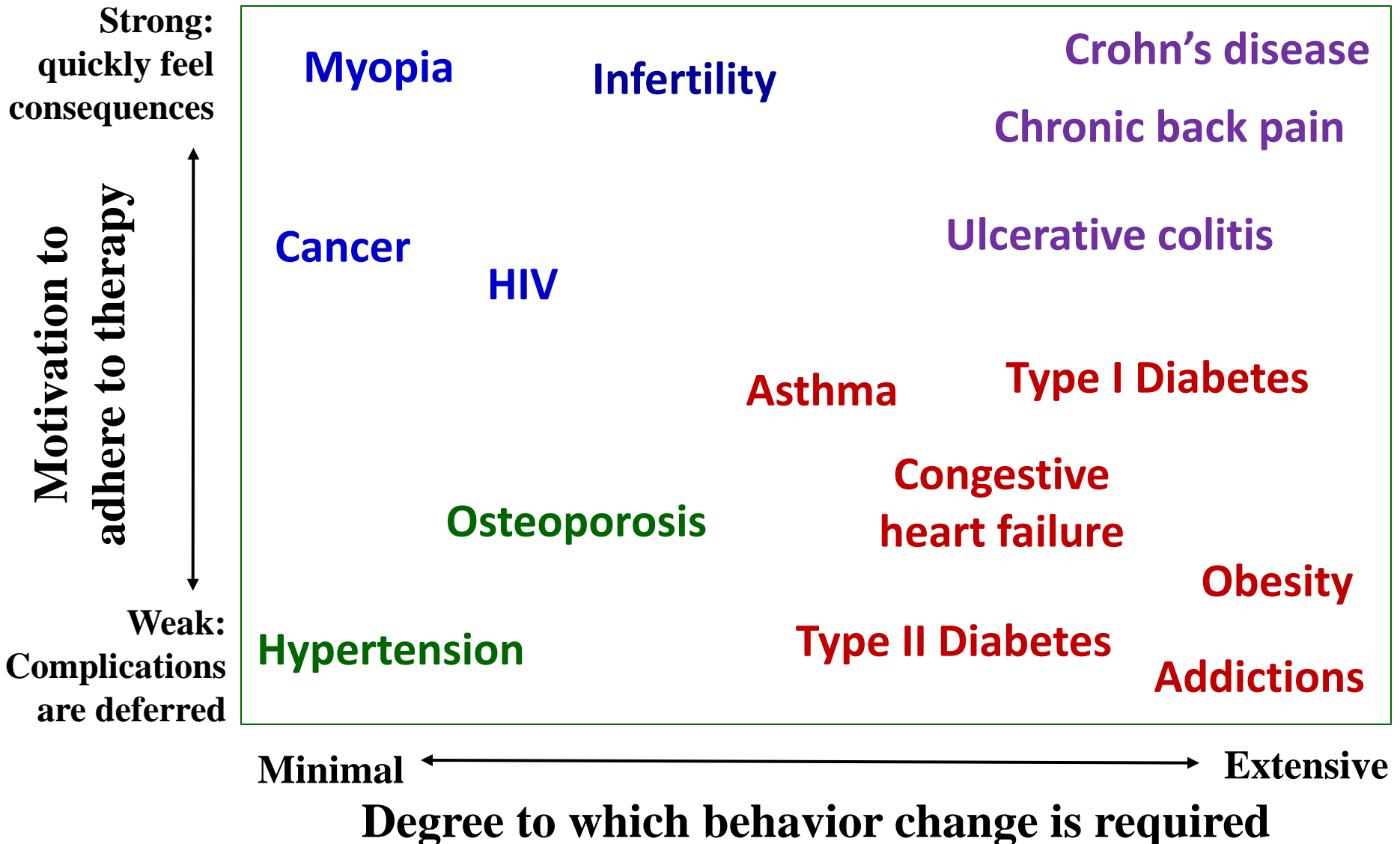

Business models for ongoing care

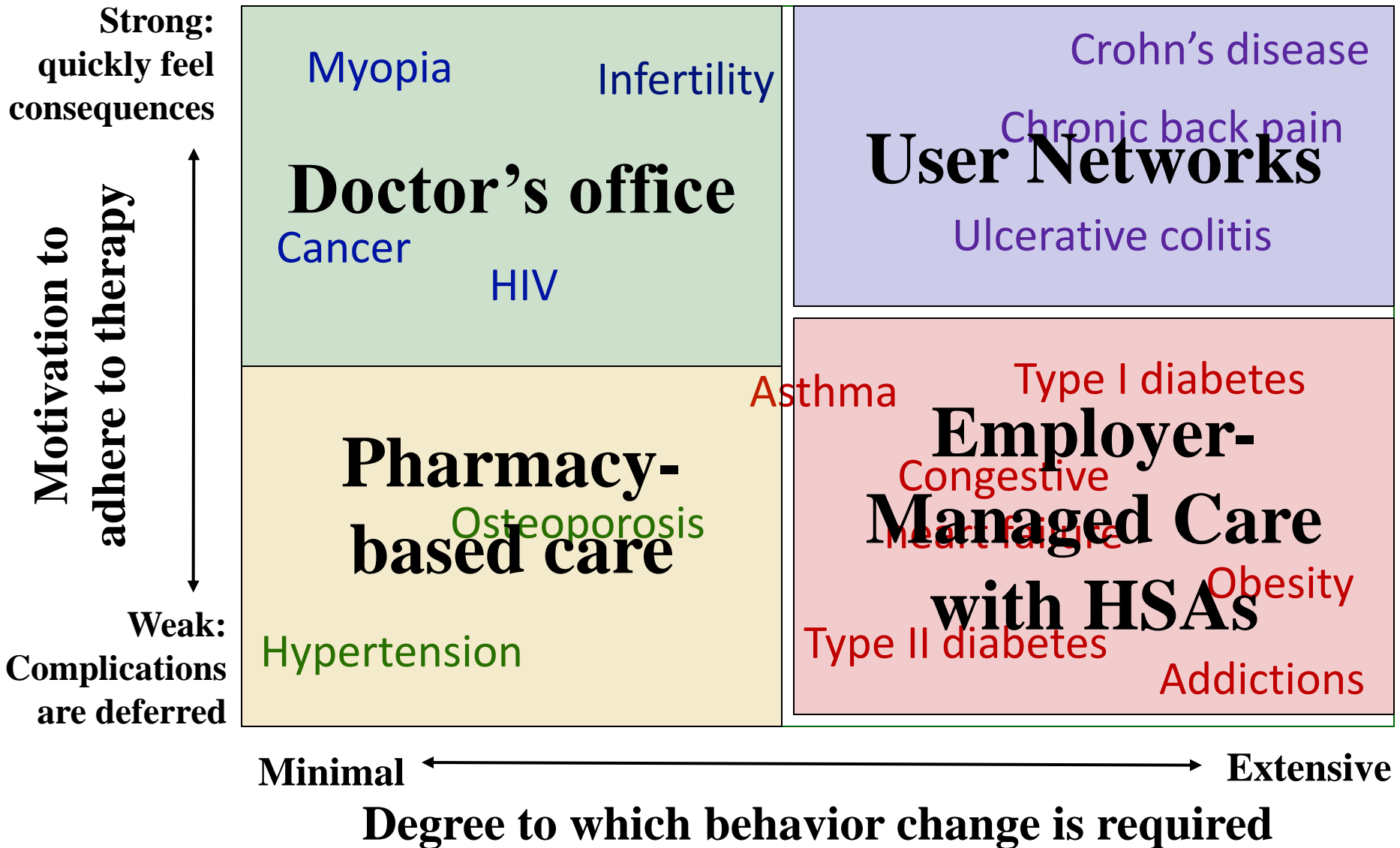

Changes in boundaries

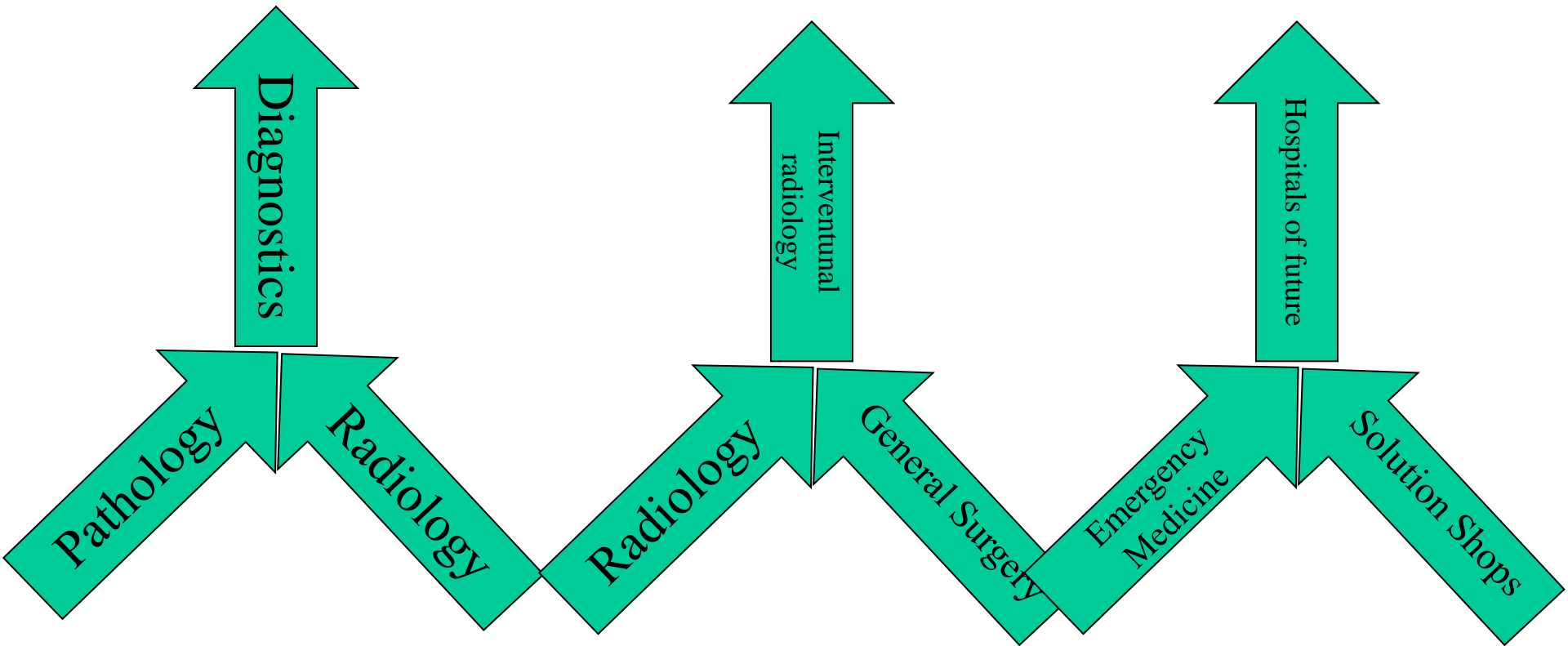

Disruption of disciplines

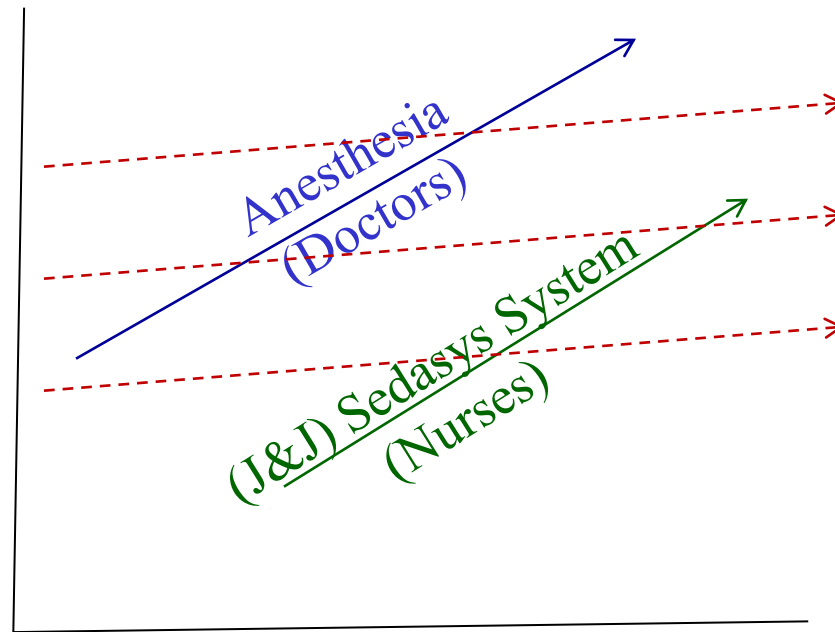

Over time, the organizational structure comes to mirror the established product's architecture.

Product Architecture

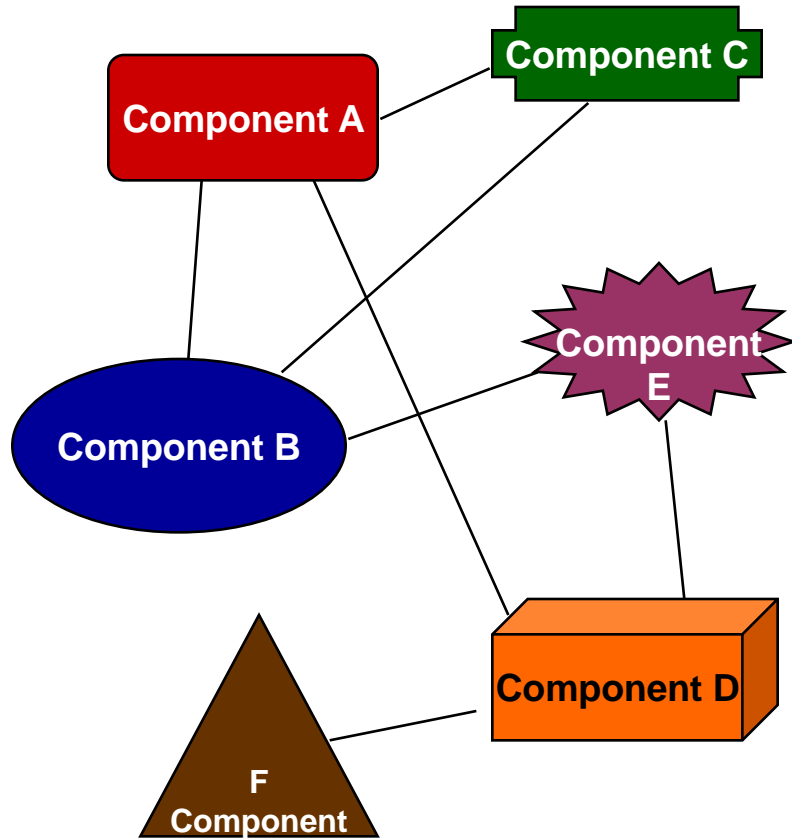

Organizational Structure & Interaction Patterns

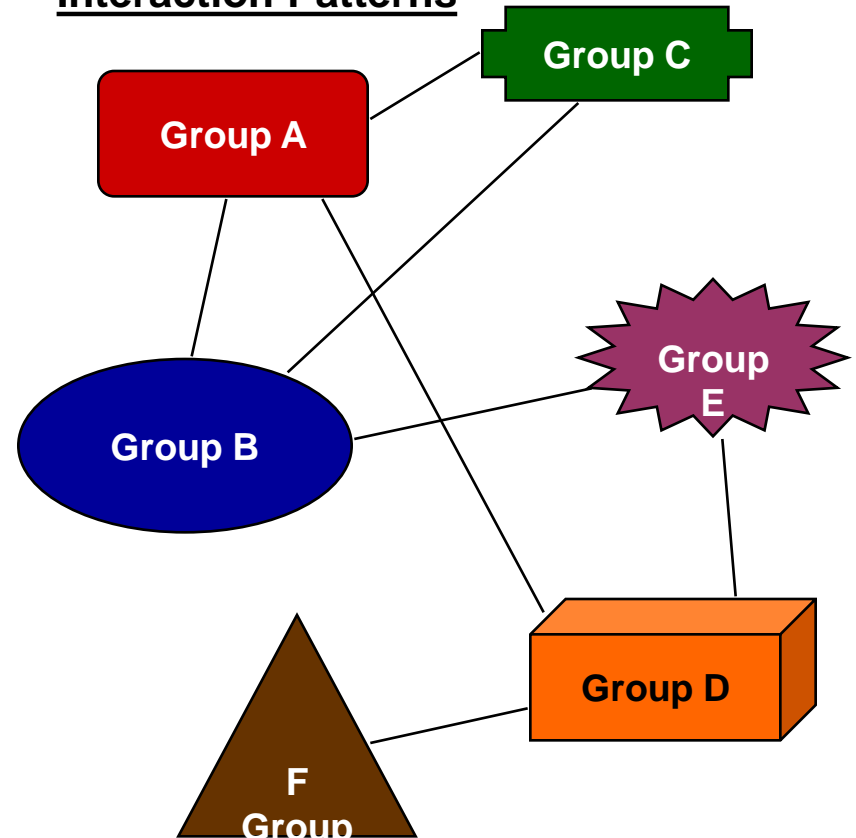

A Framework for Organizing the Development and Commercialization of New Products and Services

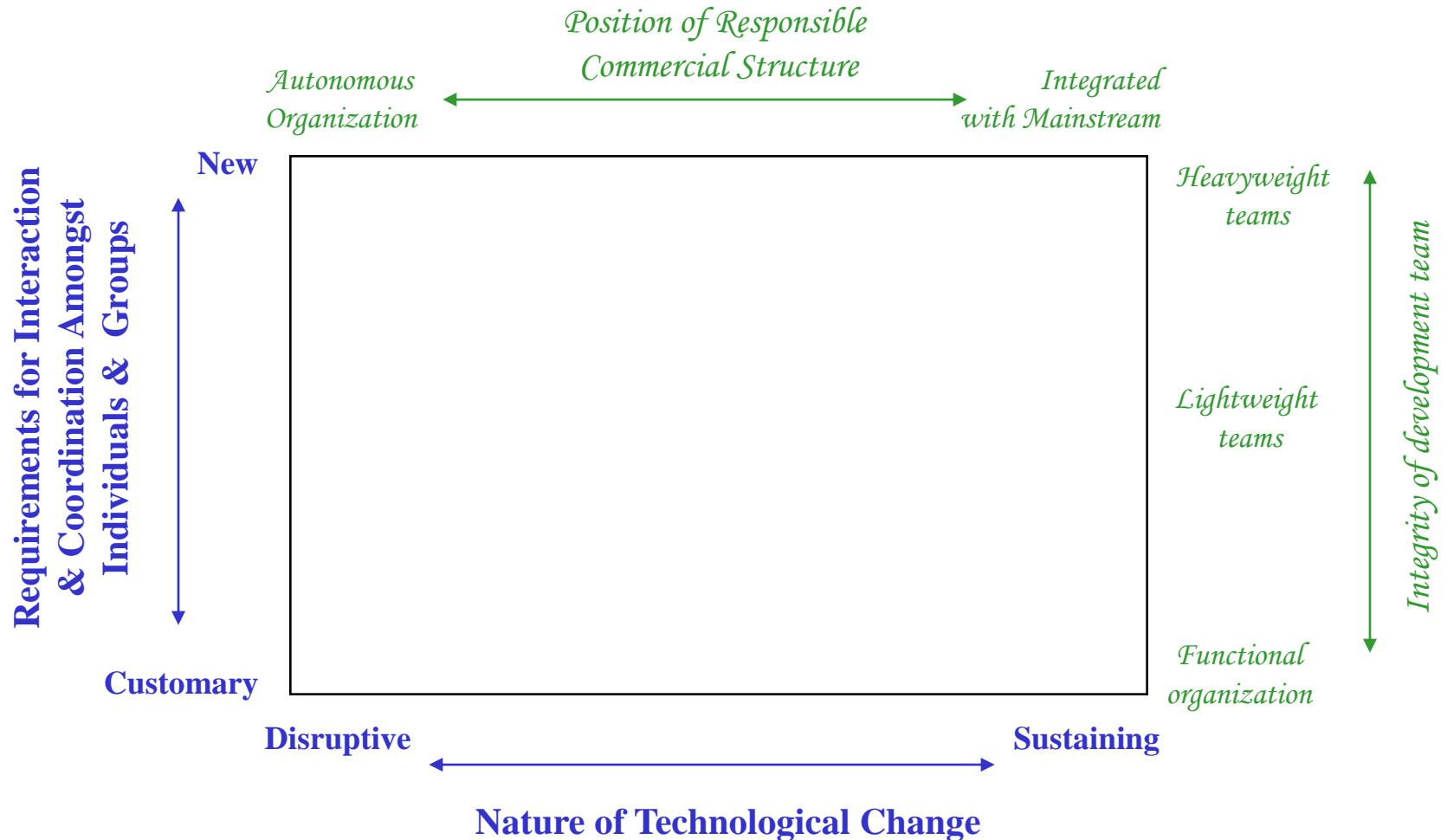

Functional Team

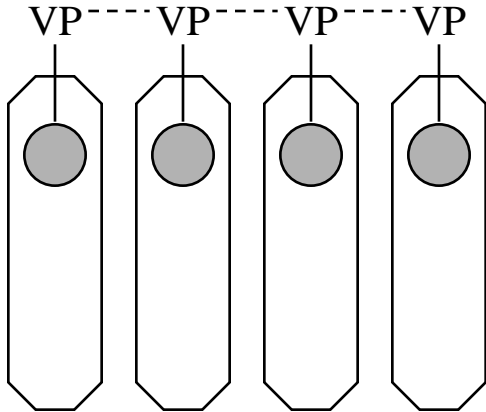

Lightweight Team

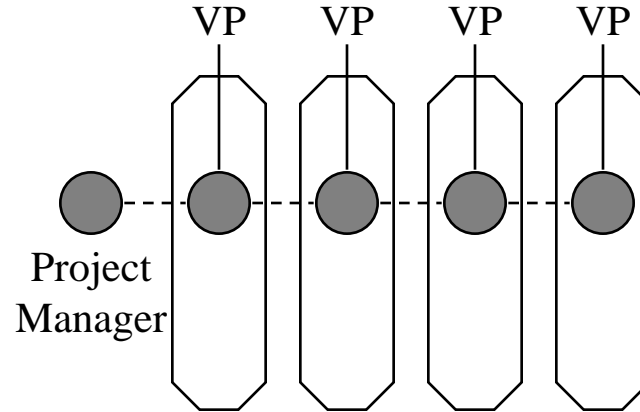

Heavyweight Team

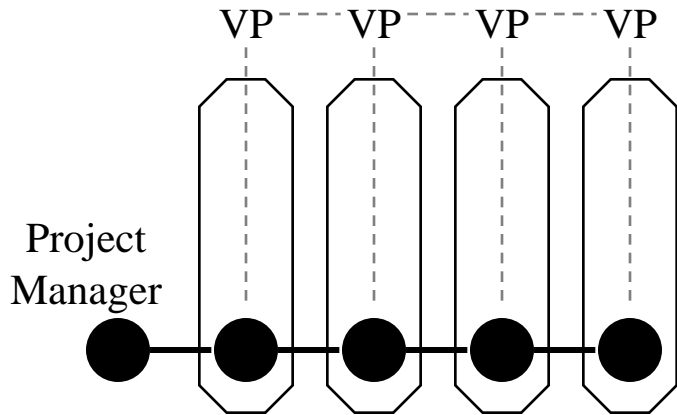

Autonomous Team

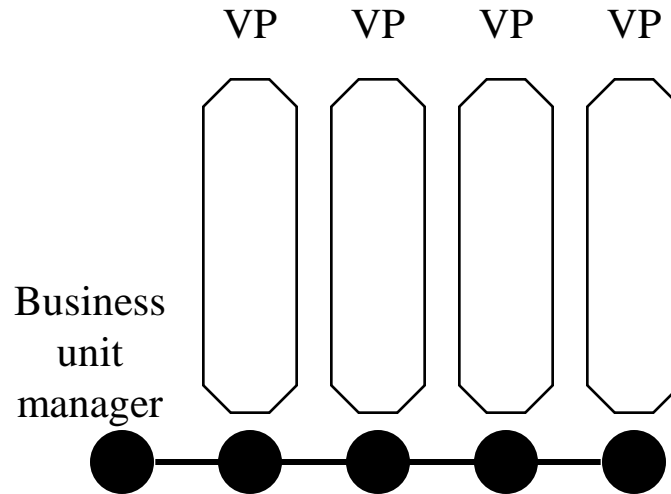

Electronic medical records cannot be pushed into use. They will simply sit unused on a disk drive, rather than in a paper file.

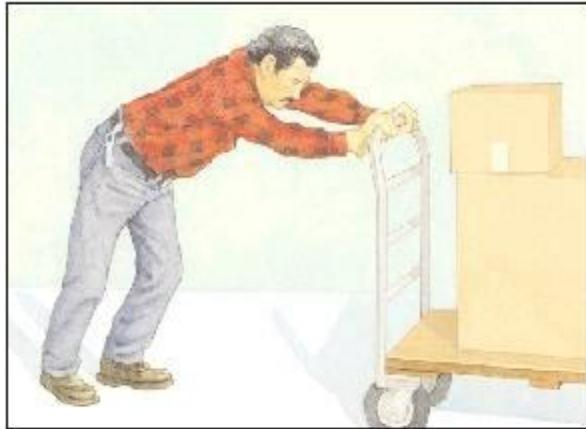

Doctors will pull EMRs into use when applications are developed that help doctors get jobs done that they are trying to do.



Outsourcing often sets in motion disruptive business model liquidation

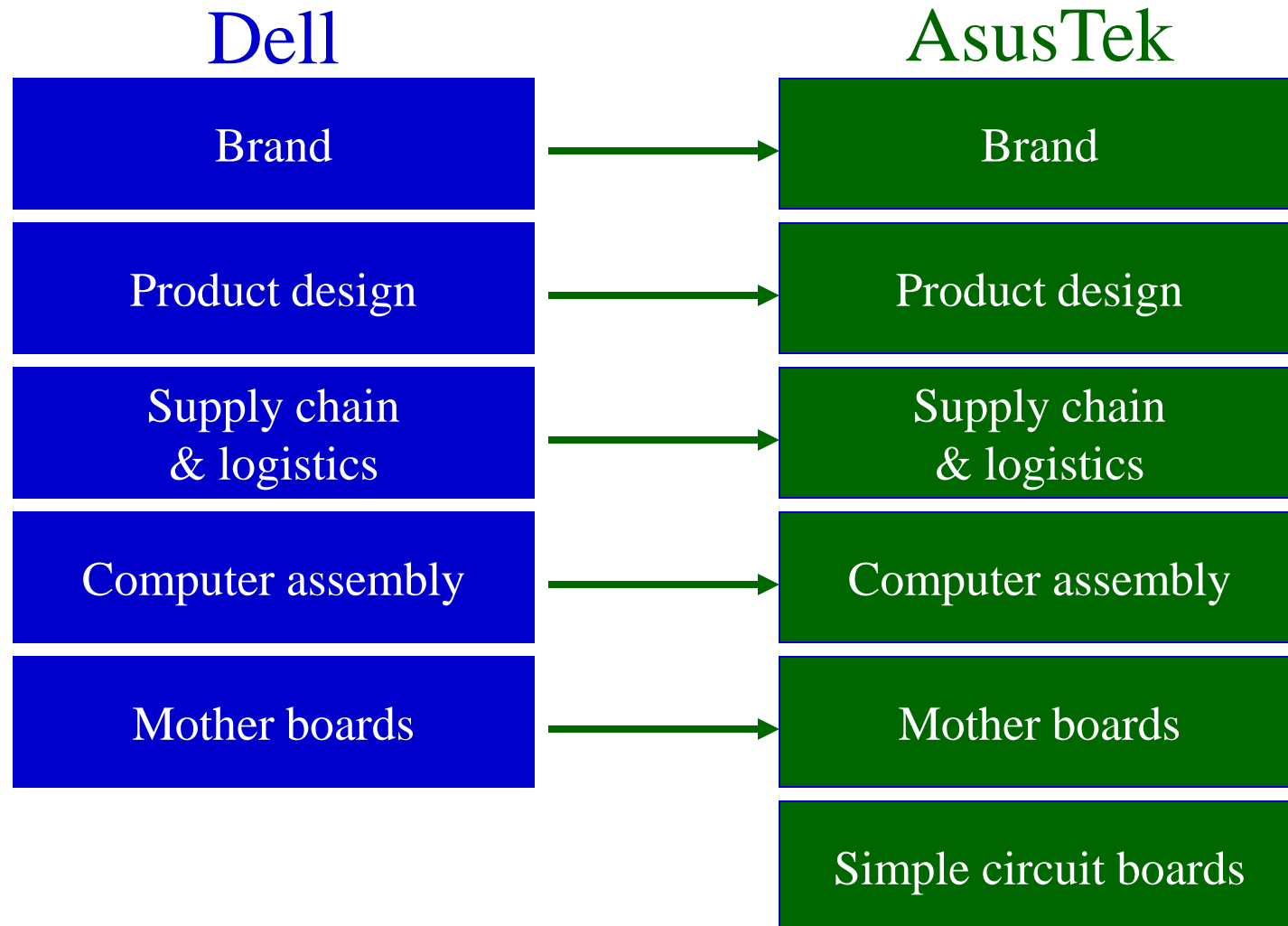

Outsourcing often sets in motion disruptive business model liquidation

